

TRW-1031D

10.4" Industrial Panel PC for railway TCMS solution



Features

- 10.4" 800*600 resolution high-brightness display monitor with touch screen (sunlight readable optional);
- Onboard Intel® ATOM™ N455/D525 processor, 1GB (supports up to 2GB) onboard memory;
- The chassis is shaped by Al-alloy. The front panel reaches IP65 protection grade, and the rear part reaches IP44;
- 2 x M12-D 10/100Mb LAN, upgradable to 1000Mb (M12-A USB optional);
- DC16V~160V or DC60-160V input, to meet power supply requirements of different users;
- PC104 slot, expandable to MVB, CANOpen, Profibus expansion cards;
- 4 x DB9 isolated COM port; 2 x RS232, 2 x RS422/485.

Specifications

Display Features

Display Screen	10.4" TFI LCD
Resolution	800 x600
Brightness	400cd/m2 (800cd/m2 optional)
Contrast Ratio	700:1
Touch Screen	5-wire resistive wide temperature screen

System

Processor	Onboard Intel® ATOM™ N455/D525 processor
Chipset	Intel® ATOM™ N455/D525 + ICH8M
Memory	Onboard DDRIII 800MHZ 1GB memory (supports up to 2GB)
Storage	4G CF card

Ethernet

Speed	2 x M12-D 10/100Mb
Connector	RJ45

I/O Interface

USB	2 x USB2.0 port, one supports M12-A USB optional
Serial Port	4 x DB9 isolated COM port: 2 x RS232, 2 x RS422/485
KB/MS	N/A
CAN	2 x CAN or MVB
PS/2	1 x PS/2

Mechanical and Environment

Dimensions (L×W×H)	345mm x 227mm x 108mm
Dimensions for openings (W×H)	282mm x 205mm
Reliability	MTBF ≥10000H; MTTR ≤30min
Safety	GJB4943
IP Level(front panel)	Front Panel IP65, Rear Panel IP44
Operating Temperature	-25°C~70°C
Storage Temperature	-40°C~70°C
Operating Humidity	5%~90% 40°C (non-condensing)

Power

Power Supply	24V DC/110V DC (UN)
Power Consumption	60W

Operating System

Windows OS	Win XP
Embedded OS	Linux

Test

Vibration	IEC61373-2010 CLASS B
Shock	IEC61373-2010 CLASS B
EMC/EMI	EMC:EN55022 CLASS A EMI:EN61000-4-2(3,4,5,6) Level

Dimensions

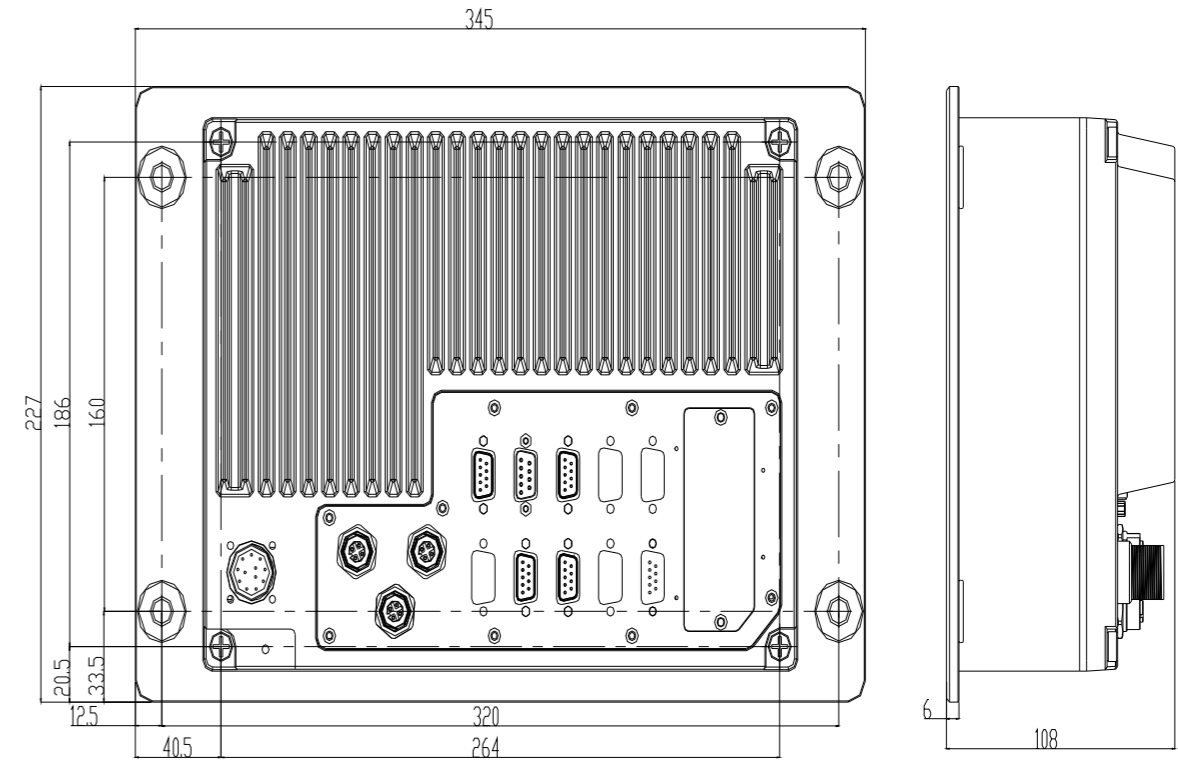

Ordering Information

Part Number	Model Number	Description
To be specified	TRW-1031D-01	10.4" display monitor for railway (resolution 800*600)/Intel ATOM N455 CPU 1.66G clock frequency/1G DDR3 memory/4GB CF/4 x COM port/2 x USB /2 x M12-D LAN port/1 x VGA/1 x PS/2/ 16-160V DC power supply/Al-alloy chassis/touch screen/front panel without button
To be specified	TRW-1031D-02	10.4" sunlight readable display monitor for railway (resolution 800*600)/Intel ATOM N455 CPU 1.66G clock frequency/1G DDR3 memory/4GB CF/4 x COM port/2 x USB/2 x M12-D LAN port/1 x M12-A USB/1 x VGA/1 x PS/2/ 16-160V DC power supply/Al-alloy chassis/touch screen/35-key panel keyboard
To be specified	TRW-1031D-03	10.4" display monitor for railway (resolution 800*600)/Intel ATOM N455 CPU 1.66G clock frequency/1G DDR3 memory/4GB CF/4 x COM port/2 x USB /2 x M12-D LAN port/1 x VGA/1 x PS/2/ 16-160V DC power supply/Al-alloy chassis/touch screen/35-key panel keyboard